

ICC-ES Evaluation Report

ESR-2217*

Reissued July 1, 2009

This report is subject to re-examination in two years.www.icc-es.org | (800) 423-6587 | (562) 699-0543

A Subsidiary of the International Code Council®

DIVISION: 07 00 00—THERMAL AND MOISTURE PROTECTION**Section: 07 21 00—Thermal Insulation****REPORT HOLDER:****NU-WOOL COMPANY INCORPORATED**

2472 PORT SHELDON ROAD

JENISON, MICHIGAN 49428

(616) 669-0100

www.nuwool.com**EVALUATION SUBJECT:****NU-WOOL PREMIUM CELLULOSE THERMAL AND SOUND INSULATION****1.0 EVALUATION SCOPE****Compliance with the following codes:**

- 2006 *International Building Code*® (IBC)
- 2006 *International Residential Code*® (IRC)
- 2006 *International Energy Conservation Code*® (IECC)

Properties evaluated:

- Physical properties
- Thermal resistance
- Sound transmission
- Surface-burning characteristics
- Fireblocking
- Fire-resistance-rated construction
- Attic and crawl space applications

2.0 USES

Nu-Wool Premium insulation is used as nonstructural thermal- and sound-insulating material in buildings of all types of construction. The insulation is for use, as an interior finish, on or within floors, floor-ceiling or roof-ceiling assemblies, attics, crawl spaces, walls and partitions. The insulation is recognized for use in sound-transmission for wall assemblies, fireblocking and in both non-fire-resistance rated and fire-resistance-rated construction in accordance with IBC Sections 703 and 719.

3.0 DESCRIPTION

Nu-Wool Premium insulation consists of a uniform low-density mixture of recycled cellulosic fibers and

fire-retardant borate-based chemicals. The insulation has a flame-spread index of not more than 25 and a smoke-developed index of not more than 50 when tested in accordance with ASTM E 84. The insulation has a thermal resistance R-value of 3.8°F-ft²-h/Btu-in at a nominal settled density of 1.6 lb./ft³ (25.6 kg/m³). The insulation is available in both a loose-fill and spray-applied form.

4.0 INSTALLATION**4.1 General:**

Insulation must be installed in accordance with this report, the Nu-Wool Company, Inc., installation instructions and ASTM C 1015. When placed adjacent to recessed light fixtures, metal chimneys or other heat-producing elements, a permanent barrier is necessary to maintain required clearance between the item and the insulation as applicable for the fixture or appliance, unless the recessed light fixture is identified by the letters "IC" and is listed for direct contact with cellulosic insulation or the heat-producing element is listed for zero clearance to combustibles. The insulation must not be placed in areas where the temperature exceeds 180°F (83.5°C). The code official may require an approved vapor retarder to be installed in accordance with IRC Section R318.1. Protection against condensation in exterior wall assemblies must be in accordance with IECC Sections 402.5 and 502.5, as referenced by the IBC. Attic vents must not be blocked by the application of the insulation.

4.2 Nu-Wool Premium Loose-fill Insulation:

The loose-fill insulation is blown into concealed spaces of walls, partitions, or roof-ceiling or floor-ceiling assemblies; or is exposed on horizontal or sloped attic floors. The insulation is installed into its final position using a pneumatic device. The insulation may be applied to sloped attic floors, provided the slope does not exceed 5:12 (41.66% slope). The insulation is installed on attic floors at a nominal density of 1.6 pcf (25.6 kg/m³).

4.3 Nu-Wool Premium Spray-applied Insulation:

The spray-applied insulation is used for exposed applications as an interior finish on new or existing steel, wood, gypsum wallboard, aluminum, masonry or concrete substrates; for concealed application within walls and partitions; or for exposed application on horizontal or sloped attic floors. The insulation is spray-applied with water for installation on or within walls and partitions. The insulation is installed on or within walls and partitions at a density between 3.0 and 4.6 pcf (48.0 and 73.6 kg/m³) and on attic floors at a nominal density of 1.6 pcf (25.6 kg/m³).

***Corrected November 2010**

The insulation is sprayed into its final position using a pneumatic device. A fine water mist is mixed with the insulation as it passes through a specially designed nozzle. All surfaces that are to receive spray-applied insulation material must be clean, dry and free from dust, grease, oil, rust and other agents tending to reduce bonding qualities. Before enclosing in walls, the insulation must dry for a minimum of 24 hours. Nu-Wool spray-applied insulation may be applied to sloped attic floors regardless of slope.

4.4 Fire Blocking:

The insulation may be used as fire blocking in accordance with IBC Section 717.2.1 and may be used as an alternate to the fire blocking required in IRC Section R602.8.1.

The insulation may be placed in the cavity of new or existing wood stud walls and partitions in buildings classified as Type V construction with stud spacing up to 24 inches (610 mm) on center. When the insulation is installed in the cavities of existing walls and partitions that have insulation, access holes measuring from 1 inch (25.4 mm) in diameter to 6 inches (152 mm) square are cut in the wall covering at each stud space, and the plugs are removed. The existing insulation is cut and pushed away to form a minimum 16-inch-deep (406 mm) space. Nu-Wool Premium spray-applied or loose-fill insulation, as applicable, is then installed into the open space, filling the full 16-inch (406 mm) (or greater) depth and contacting all surfaces. After installation has been completed, the plugs are replaced and the wall covering is repaired.

When there is no insulation in the wall or partition, Nu-Wool Premium spray-applied insulation must fill the stud space to a minimum depth of 16 inches (406 mm).

4.5 Sound Transmission:

The following wall assemblies have a Sound Transmission Class (STC) of 50 or greater:

4.5.1 Double Wood Stud Wall, Assembly 1: The assembly is as described in Sections 4.6.2 and 4.6.3. The minimum wall weight must be 10.3 lb/ft² (53 kg/m²).

4.5.2 Double Wood Stud Wall, Assembly 2: The assembly is as described in Section 4.6.4. The minimum wall weight must be 20.2 lb/ft² (986 kg/m²).

4.6 Fire-resistance-rated Wall Assemblies:

4.6.1 General: Nu-Wool Premium spray-applied insulation may be installed in stud cavities of fire-resistance-rated wood stud assemblies incorporating gypsum wallboard or gypsum sheathing as described in Sections 4.6.2, 4.6.3 and 4.6.4 of this report. Time assigned for additional protection of wood-stud walls is 15 minutes when calculating fire resistance in accordance with Section 721.6 of the IBC.

4.6.2 Two-hour Load-bearing Double Wood Stud Wall Assembly: The assembly consists of two rows of nominally 2-by-4, No. 2 wood studs spaced at 16 inches (406 mm) on center, on separate nominally 2-by-4 wood plates placed 1 inch (25.4 mm) apart. The studs are staggered 8 inches (203 mm) from the studs on the opposite side. Horizontal blocking, constructed from nominally 2-by-4 solid sawn lumber, must be installed at mid-height of the wall and staggered for end nailing with two 16d sinker nails at each end. One layer of ⁵/₈-inch-thick (15.9 mm), Type C gypsum wallboard manufactured by United States Gypsum Company must be attached vertically or horizontally with vertical joints over studs on both sides of the wall with 6d cement-coated nails (¹/₈ inches long, 0.0915 inch shank diameter, ¹/₄ inch

head diameter) spaced at 7 inches (177.8 mm) on center. The dry density of the Nu-Wool Premium insulation must be 4.58 pcf (73.3 kg/m³). Wallboard joints and screw heads must be taped and sealed with joint compound in accordance with ASTM C 840. See Figure 1.

4.6.3 Three-hour Load-bearing Double Stud Wall Assembly:

The assembly is as described in Section 4.6.2 except that two layers of ⁵/₈-inch-thick (15.9 mm), Type C gypsum board manufactured by United States Gypsum Company are attached on both faces of the assembly. Fastener length must be increased to account for the thickness of the second layer. See Figure 2.

4.6.4 Two-hour Load-bearing Double Stud Wall Assembly:

The assembly consists of two rows of nominally 2-by-4, No. 2 spruce-pine-fir wood studs, spaced at 16 inches (406 mm) on center, installed on separate wood plates. The studs are staggered 8 inches (203 mm) from the studs on the opposite side. One layer of ⁵/₈-inch-thick, Type X gypsum board must be installed vertically on the interior and exterior surfaces of the wall studs, and between the two stud rows (three layers, total). The gypsum board is attached to the wood studs with No. 6 by ¹/₂-inch bugle head drywall screws spaced 6 inches (152.4 mm) on center at the perimeter and 12 inches (304.8 mm) on center in the field. The stud cavities are filled with Nu-Wool Premium spray-applied insulation. The dry density of the Nu-Wool Premium must be 4.58 pcf (73.3 kg/m³). Wallboard joints and screw heads must be taped and sealed with joint compound in accordance with ASTM C 840. See Figure 3.

5.0 CONDITIONS OF USE

The Nu-Wool Premium insulation described in this report complies with, or is a suitable alternative to what is specified in, those codes listed in Section 1.0 of this report, subject to the following conditions:

- 5.1 Installation must comply with this report, the manufacturer's published installation instructions, and the applicable code. In the event of a conflict between this report and the manufacturer's published installation instructions, this report governs.
- 5.2 The insulation may be used in fire-resistance-rated construction when installed in accordance with Section 4.6 of this report.
- 5.3 The insulation may be installed in noncombustible construction without affecting the noncombustible recognition.
- 5.4 The installer must provide the code official a signed and dated statement describing the type of insulation installed, including thickness, coverage area, R-value and number of bags or pounds of insulation installed.
- 5.5 Nu-Wool Premium insulation is manufactured by Nu-Wool Co., Inc., at their manufacturing facility in Jenison, Michigan.

6.0 EVIDENCE SUBMITTED

- 6.1 Reports of tests in accordance with CPSC 16 CFR, Parts 1209 and 1404.
- 6.2 Reports of surface-burning characteristic tests in accordance with ASTM E 84.
- 6.3 Reports of thermal transmission testing in accordance with ASTM C 518.
- 6.4 Reports of sound transmission tests in accordance with ASTM E 90 and ASTM E 413.

- 6.5 Reports of fire endurance tests in accordance with ASTM E 119.
- 6.6 Engineering analysis for fire-resistance-rated wall assemblies.
- 6.7 Reports of comparative fire tests of fireblocking assemblies following a modified ASTM E 119 procedure.
- 6.8 Quality documentation.

7.0 IDENTIFICATION

Each bag of insulation is identified by a label bearing the Nu-Wool Company, Inc., name and address, product name, manufacturing date, and evaluation report number (ESR-2217). Additionally, each bag must bear a label with information required by CPSC 16 CFR, Parts 1209 and 1404. Jobsite labeling in floor/ceiling applications must comply with IRC Section N1101.4.1.

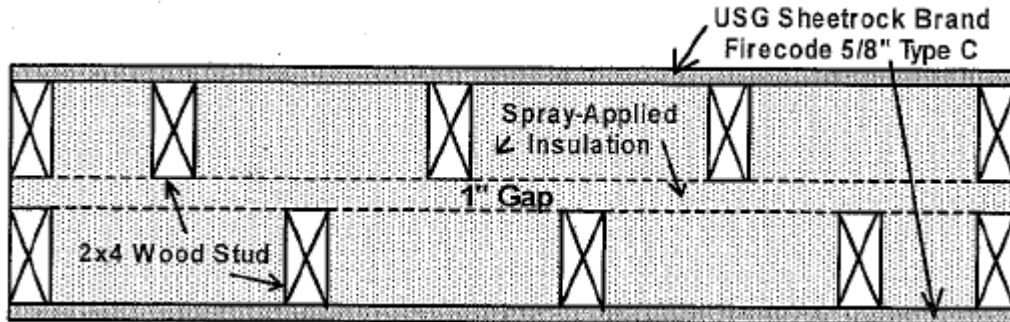

FIGURE 1—TWO-HOUR LOAD-BEARING DOUBLE WOOD STUD WALL ASSEMBLY (SEE SECTION 4.6.2)

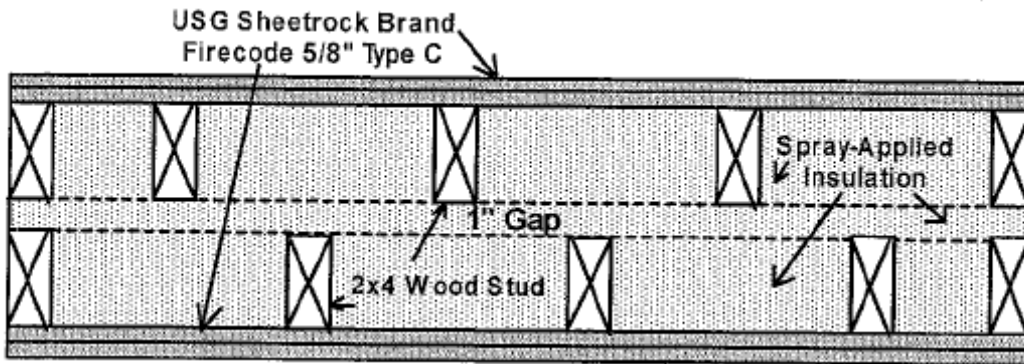

FIGURE 2—THREE-HOUR LOAD-BEARING DOUBLE WOOD STUD WALL ASSEMBLY (SEE SECTION 4.6.3)

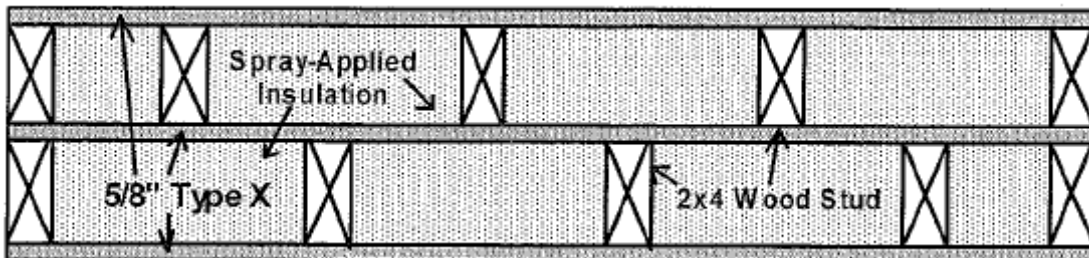

FIGURE 3—TWO-HOUR LOAD-BEARING DOUBLE WOOD STUD WALL ASSEMBLY (SEE SECTION 4.6.4)

ICC-ES SAVE: Verification of Attributes Report™**VAR-1005**

Reissued April 1, 2010

This report is subject to re-examination in two years.www.icc-es.org/save | 1-800-423-6587 | (562) 699-0543 A Subsidiary of the International Code Council®**DIVISION: 07—THERMAL AND MOISTURE PROTECTION**
Section: 07 21 00—Thermal Insulation**REPORT HOLDER:****NU-WOOL CO., INC.**
2472 PORT SHELDON ROAD
JENISON, MICHIGAN 49428
(616) 669-0100
www.nuwool.com
chrenka@nuwool.com**EVALUATION SUBJECT:****NU-WOOL WALLSEAL PREMIUM THERMAL AND
SOUND INSULATION****1.0 EVALUATION SCOPE****Compliance with the following evaluation guideline:**

ICC-ES Evaluation Guideline for Determination of Recycled Content of Materials (EG101), dated October 2008.

Compliance eligibility with the applicable sections of the following green building rating systems, standards and codes:

- ICC 700-2008, National Green Building Standard (see Table 2 for details)
- LEED 2009 for New Construction and Major Renovations (LEED NC) (see Table 3 for details)
- LEED for Homes 2008 (see Table 4 for details)
- LEED 2009 for Schools New Construction and Major Renovations (see Table 5 for details)
- 2008 California Green Building Standards Code (CGSBC), Title 24, Part 11 (see Table 6 for details)
- Green Globes for New Construction (see Table 7 for details)

2.0 USES

Nu-Wool WALLSEAL Premium insulation is used as non-structural thermal- and sound-insulating material in buildings. The insulation is used on or within floors, floor-ceiling or roof-ceiling assemblies, attics, crawl spaces, walls and partitions.

3.0 DESCRIPTION

Nu-Wool WALLSEAL Premium insulation consists of a uniform low-density mixture of recycled cellulosic fibers and fire-retardant borate-based chemicals. The insulation

is available in both a loose-fill and spray-applied form. The product contains the recycled content type and amount set forth in Table 1 of this report.

4.0 CONDITIONS**4.1 Code Compliance:**

See ICC-ES evaluation report [ESR-2217](#) for compliance with code requirements.

4.2 Green Rating Systems, Standards and Codes Eligibility:

The information presented in Tables 2 through 7 of this report provides a matrix of areas of evaluation and corresponding limitations and/or additional project-specific requirements, and offers benefit to individuals who are assessing eligibility for credits or points.

The final interpretation of the specific requirements of the respective green building rating systems, standards and/or codes rests with the developer of that specific rating system, standard or code, or the Authority Having Jurisdiction, as applicable.

Compliance with the items noted as “Verified Attribute” is subject to any conditions noted in Tables 2 through 7. The user is advised of the project-specific provisions that may be contingent upon meeting specific conditions, and the verification of those conditions is outside the scope of this report. Rating systems or standards may provide supplemental information as guidance.

5.0 BASIS OF EVALUATION

The information in this report, including any “Verified Attribute,” is based upon the following supporting documentation:

- ICC-ES Evaluation Guideline for Determination of Recycled Content of Materials (EG101) [Evaluation applies to ICC 700 Section 604.1; LEED NC MR Credit 4; LEED for Homes MR Credit 2.2; LEED Schools MR Credit 4; CGSBC Section 705.4; Green Globes Section 10.2.1.1]

6.0 IDENTIFICATION

Each bag of insulation is identified by a label bearing the Nu-Wool Company, Inc., name and address, product name, manufacturing date and the VAR number (VAR-1005).

TABLE 1—RECYCLED CONTENT BY WEIGHT SUMMARY

PRODUCT	% PRE-CONSUMER RECYCLED CONTENT	% POST-CONSUMER RECYCLED CONTENT	% IN-PROCESS RECYCLED CONTENT—AS IS	% IN-PROCESS RECYCLED CONTENT—TREATED	% TOTAL RECYCLED CONTENT
Nu-Wool WALLSEAL	20	65.83	0	0	85.83

TABLES 2 THROUGH 7

Section #	Section Intent	Possible Points	Conditions of Use to Qualify for Points	Finding
TABLE 2—SUMMARY OF AREA OF ELEGIBILITY WITH THE ICC-700 NATIONAL GREEN BUILDING STANDARD				
604.1	Use two or more major and/or minor building materials containing recycled content	1 3 max	1, 2 or 3 points may be earned when products are used with another minor building component with recycled content of 25% < 50%; 50% < 75%; or ≥ 75%, respectively	•
TABLE 3—SUMMARY OF AREA OF ELEGIBILITY WITH USGBC'S 2009 LEED FOR NEW CONSTRUCTION AND MAJOR RENOVATIONS				
MR 4	Recycled content	1 2 max	To earn 1 point use materials with recycled content such that the sum of post-consumer recycled content plus 1/2 of the pre-consumer content constitutes at least 10%, based on cost, of the total value of the materials in the project. To earn 2 points use 20% or more. Nu-Wool's recycled content equals 75.83% using this formula	•
TABLE 4—SUMMARY OF AREA OF ELEGIBILITY WITH USGBC'S LEED FOR HOMES 2008				
MR 2.2	Recycled content	0.5	To earn 0.5 point use insulation with recycled content of either 10% post-consumer or 95 % post-industrial (pre-consumer). Nu-Wool's recycled content equals 75.83% using this formula	•
TABLE 5—SUMMARY OF AREA OF ELEGIBILITY WITH USGBC'S LEED 2009 FOR SCHOOLS NEW CONSTRUCTION AND MAJOR RENOVATIONS				
MR 4	Recycled content	1 2 max	To earn 1 point use materials with recycled content such that the sum of post-consumer recycled content plus 1/2 of the pre-consumer content constitutes at least 10%, based on cost, of the total value of the materials in the project. To earn 2 points use 20% or more. Nu-Wool's recycled content equals 75.83% using this formula	•
TABLE 6—SUMMARY OF AREA OF ELEGIBILITY WITH THE 2008 CALIFORNIA GREEN BUILDING STANDARDS CODE				
705.4	Recycled content	N/A	Use materials with a postconsumer or preconsumer recycled value for a minimum of 10% of the total value, based on estimated cost of materials on the project	•
TABLE 7—SUMMARY OF AREA OF ELEGIBILITY WITH GBI'S GREEN GLOBES FOR NEW CONSTRUCTION				
10.1.2	Materials content - Assemblies	1 8 max	Recycled post-consumer or post-industrial (pre-consumer) content materials accounted for 1% to 20% or more of building materials. Percentage is calculated as 100 x A (total cost or weight of recycled content materials) ÷ B (total cost or weight of all building materials)	•
•	= Verified attribute			